



# RECYCLING EQUIPMENT RANGE

KEY FEATURES AND TECHNICAL DATA





**WE  
MAKE  
RECYCLING  
EASY.**







over 3000 employees

9 production plants and growing

Distribution to 80 countries worldwide on 6 continents

Our own Research and Development Centre

Own production for supply chain disruptions

Fast service and after-sales

# PRONAR

Pronar is a company with over 30 years of production and sales experience and declared as one of the fastest developing companies in Central and Eastern Europe. We are a leader in the production of agricultural, recycling and municipal machinery, disc wheels (biggest manufacture in Europe, second biggest in the world), driving systems, gears and pneumatic and hydraulic components. All crucial components and whole machines are manufactured in-house in eight modern factories. Pronar employs over 3000 people, from which 170 are highly qualified engineers. They are supported by results of research conducted by own research and development center. An undoubted advantage of Pronar is its own airfield and a fleet of airplanes used for quick business communication and emergency service cases.

Pronar constantly invests in new factories and high-tech manufacturing equipment. Every year we implement new production techniques like very precise machining centers, welding robots, water jets, 3D laser cutters and welders. As a result, our customers can be sure that their machines were made with the utmost care and precision.

Products carrying Pronar logo can be found in over 80 countries around the world and on every continent - whole Europe, USA, Canada, Mexico, Chile, China, South Korea, Japan, Australia and many others. Customers appreciate their high quality, ease of use and service, as well as very good after-sales support. Every day we are driven by a passion to create innovative solutions that allow us to compete with the largest players in global markets.





pronar-recycling.com

MRW 2.75g



U M B A G B  
STAF  
M A S I N I C  
D A L A R D I N A  
D I V E R S I F I K A S I  
D I N A B E R P A N J A R A N





# MOBILE SHREDDERS

Mobile slow-speed shredders are first in line as a primary shredders. They tackle the toughest, often contaminated material. Their task is to pre-shred the processed material and thus reduce its volume. As a result, the material is prepared for a second stage of shredding or easier sorting. In the appropriate configuration of the slow-speed shredder, it is possible to use the processed material processed as the final product. Pronar shredders are manufactured using the latest technologies. The entire process uses welding robots to weld frames and shafts, as well as water cutters that guarantee keeping the key parameters of the steel being cut without the need for additional hardening. Elements exposed to particularly high stress are subject to special quality control of the steel and welds used. The use of high-end hydraulic systems guarantees their reliability.

## KEY FEATURES

- | the possibility of easy adjustment of the machine to the material being processed
- | high strength of the structure thanks to the use of high grades of steel
- | various types of shafts depending on the material being processed
- | extensive equipment as standard
- | production with the use of welding robots as well as laser and water cutters





# mobile slow-speed shredder MRW 2.1010

The Pronar MRW 2.1010 slow-speed shredder is the largest machine in the offer, designed to work in large installations. Its heart is the Volvo Penta 796 HP engine (without DPF filter), which, combined with load sensing hydraulics and two hydraulic motors per shaft, allows you to deal with difficult materials. The working chamber is 2.44 m long and the chute capacity is 4.5 m<sup>3</sup>, which makes it possible to work even with large loaders. The weight of 44 tons (depending on the configuration) is a guarantee of solid construction with the use of thick steel, especially in sensitive points exposed to high stress. The MRW 2.1010 shredder is also designed for easy service. Machine draining points are located on the outside for easy access. There is also enough space inside the shredder to be able to carry out all necessary repairs in comfortable conditions.

## KEY FEATURES & BENEFITS

- | high efficiency
- | the ability to work even with difficult materials
- | homogeneous final fraction
- | only toughest steel grades guarantee solid construction
- | easy service access

## APPLICATION

- | wood
- | wood-based materials
- | municipal waste
- | large-size
- | industrial waste
- | tires
- | scrap metal
- | car bodies (without engines and axles)
- | mattresses





## TECHNICAL DATA

## MRW 2.1010

Dimensions (length/width/height) [mm]	9470/3000/3230
Weight [kg]	~44000*
Number of shafts	2
Shafts length [mm]	2440
Loading height [mm]	3230
Working chamber dimensions (length/width) [mm]	2440/2880
Hopper capacity [m <sup>3</sup> ]	~4,5
Engine	Volvo Penta 16.1, 585 kW, Stage V/Tier 4 Final

\* Weight depends on the specification of the individual piece and may be higher

## MRW 2.1010

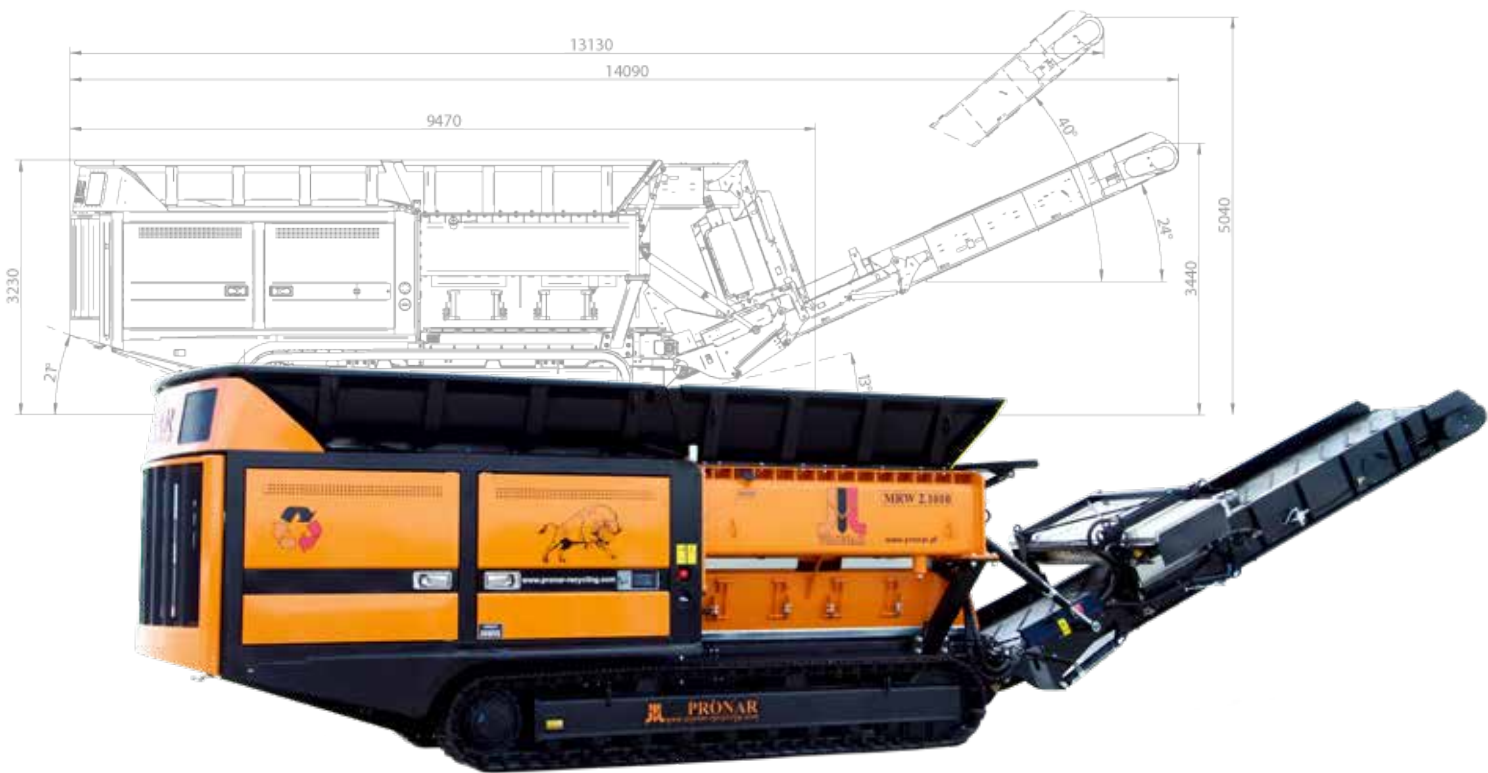



## mobile slow-speed shredders MRW 1.300 | MRW 1.300g

The single-shaft slow-speed shredder of the Pronar MRW 1.300 series is a machine designed to work in large installations. Its heart is a 3 m long shaft driven directly by a diesel engine. Basing this on hydrokinetic clutch mechanism guarantees up to 95% efficiency in power transmission. System of a tilting beam with counter knives and protection on the clutch allow you to cope with the situation of unshreddable material falling into the working chamber. The availability of screens of various sizes and steel limiters (optional equipment) mounted under the shaft allows you to adjust the size of the final fraction to the requirements. Thanks to the wheeled chassis, the machine can be transported on public roads (depending on local regulations), and the tracked chassis allows for easy maneuvering in the yard.

### KEY FEATURES & BENEFITS

- | knives replaceable with the use of generally available tools
- | high drive efficiency
- | possibility of installing screens or limiters under the shaft
- | easy service access

### APPLICATION

- | wood
- | wood-based materials
- | municipal
- | bulky
- | industrial and green waste





**TECHNICAL DATA**

	<b>MRW 1.300</b>	<b>MRW 1.300g</b>
Dimensions (length/width/height) [mm]	10140/2540/3675	8360/2540/3460
Weight [kg]	~27000*	~30000*
Number of shafts	1	1
Shafts length [mm]	3000	3000
Loading height [mm]	2870	2720
Working chamber dimensions (length/width) [mm]	3650/2200	3650/2200
Hopper capacity [m <sup>3</sup> ]	~6,4	~6,4
Engine	Volvo Penta 12.8l, 405 kW, Stage V/Tier 4 Final	Volvo Penta 12.8l, 405 kW, Stage V/Tier 4 Final

\* Weight depends on the specification of the individual piece and may be higher

## MRW 1.300



## MRW 1.300g





mobile slow-speed shredders

MRW 2.85 | MRW 2.85h  | MRW 2.85g

The slow-speed shredders of the Pronar MRW 2.85 series are machines designed with efficiency in mind for operation in medium-sized installations. Thanks to the availability of the hook chassis (meeting the DIN 30722-1 standard), tracked and wheeled chassis, each customer can choose a machine exactly suited to his needs. The hook version is undoubtedly an advantageous purchase price. The wheeled version is perfect for customers who often transport the machine on public roads. The tracked version is undoubtedly easy to move around the yard, while maintaining the dimensions that allow the machine to be easily transported on a low-loader trailer. The 420hp CAT engine in the machine is working with load sensing hydraulics for low fuel consumption. The hook version can be equipped with an electric motor that guarantees low operating costs and enables continuous operation inside the building.

## KEY FEATURES & BENEFITS

- | homogeneous size of final fraction
- | various chassis versions
- | quick set-up time
- | electric motor available

## APPLICATION

- | wood
- | wood-based materials
- | municipal waste
- | bulky
- | industrial
- | construction waste
- | asphalt
- | tires
- | thin-walled scrap





## TECHNICAL DATA

	MRW 2.85	MRW 2.85g	MRW 2.85h
Dimensions (length/width/height) [mm]	9010/2550/3960	7757/2550/3240	7350/2575/2740
Weight [kg]	~26000*	~26380*	~21500*
Number of shafts	2	2	2
Shafts length [mm]	1700	1700	1700
Loading height [mm]	3220	3030	2480
Working chamber dimensions (length/width) [mm]	1720/2340	1720/2340	1720/2340
Hopper capacity [m <sup>3</sup> ]	~3	~3	~3
Engine	CAT C9.3B, 310 kW, Stage V/Tier 4 Final; CAT C9, 280 kW, Tier 3)	CAT C9.3B, 310 kW, Stage V/Tier 4 Final; CAT C9, 280 kW, Tier 3)	CAT C9.3B, 310 kW, Stage V/Tier 4 Final; CAT C9, 280 kW, Tier 3) ABB, 250 kW + 22 kW

\* Weight depends on the specification of the individual piece and may be higher

## MRW 2.85

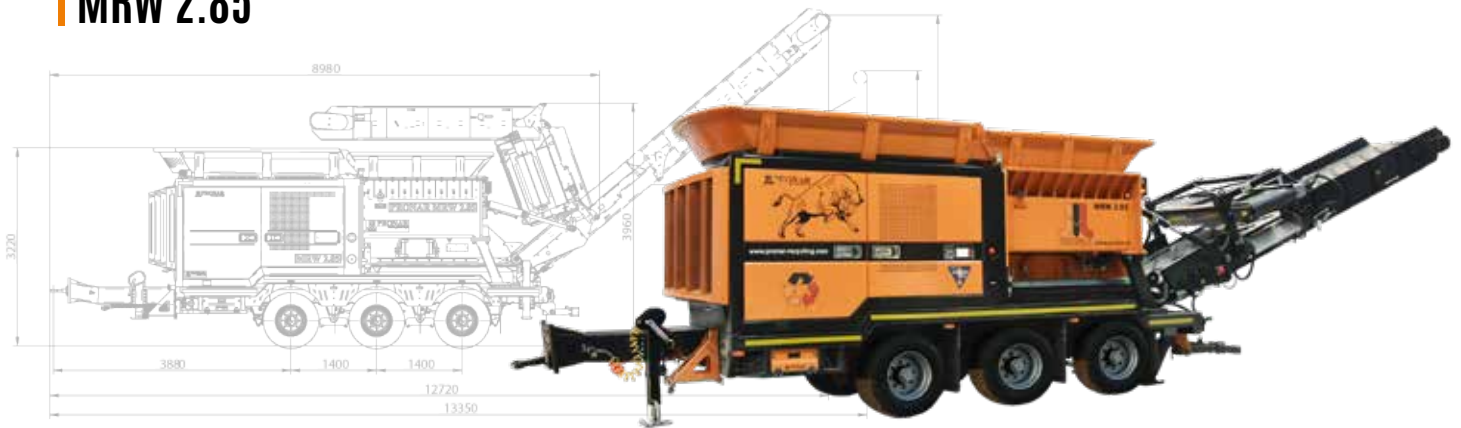

## MRW 2.85g

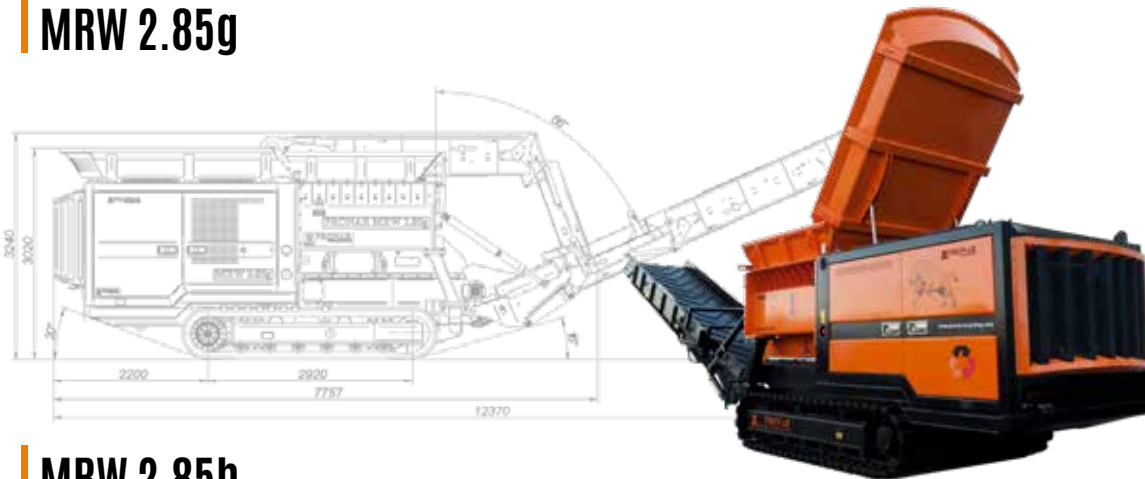

## MRW 2.85h

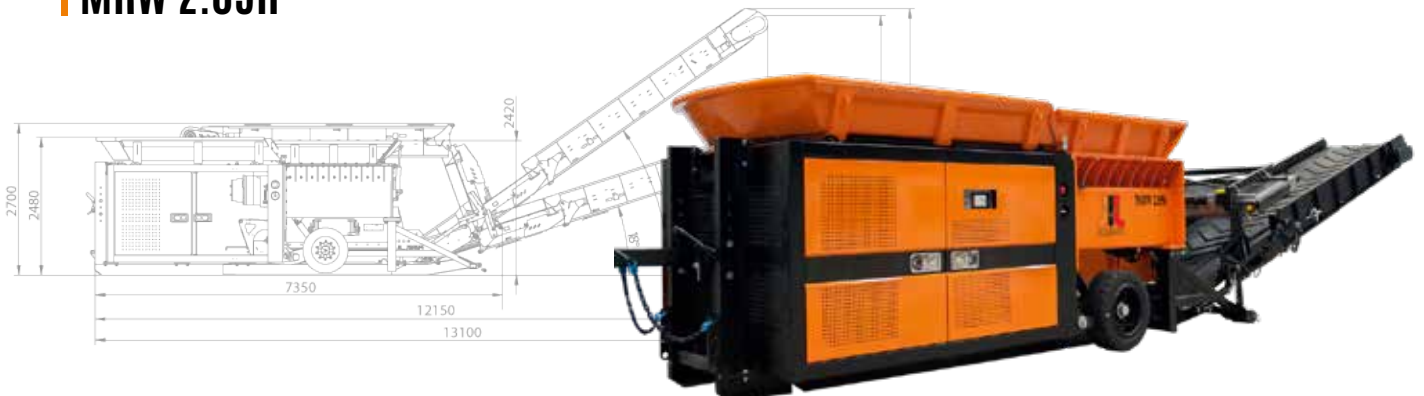



## mobile slow-speed shredders MRW 2.75h | MRW 2.75g

The slow-speed shredders of the Pronar MRW 2.75 series are machines designed for companies that need compact equipment. Various types of easily replaceable shafts are available, allowing the shredder to be adapted to the task at site. Pronar MRW 2.75 is available with a hook or tracked chassis. The 285 HP Volvo Penta engine installed in the machine allows for smooth operation even with tougher materials. Together with the load sensing hydraulics, it is possible to achieve high performance without high fuel consumption.

### KEY FEATURES & BENEFITS

- | easily replaceable shafts in the cassette
- | compact size
- | flexible motor with high power
- | high discharge from the feeder

### APPLICATION

- | wood
- | wood-based materials
- | municipal waste
- | bulky
- | industrial
- | construction waste
- | c&d waste
- | asphalt
- | tires
- | thin-walled scrap





## TECHNICAL DATA

	MRW 2.75h	MRW 2.75g
Dimensions (length/width/height) [mm]	6700/2486/2740	6642/2491/2990
Weight [kg]	~16000*	~16500*
Number of shafts	2	2
Shafts length [mm]	1550	1550
Loading height [mm]	2520	2750
Working chamber dimensions (length/width) [mm]	1620/2340	1620/2340
Hopper capacity [m <sup>3</sup> ]	~2,5	~2,5
Engine	Volvo Penta 7.7i, 210 kW, Stage V/Tier 4 Final	Volvo Penta 7.7i, 210 kW, Stage V/Tier 4 Final

\* Weight depends on the specification of the individual piece and may be higher

## MRW 2.75h

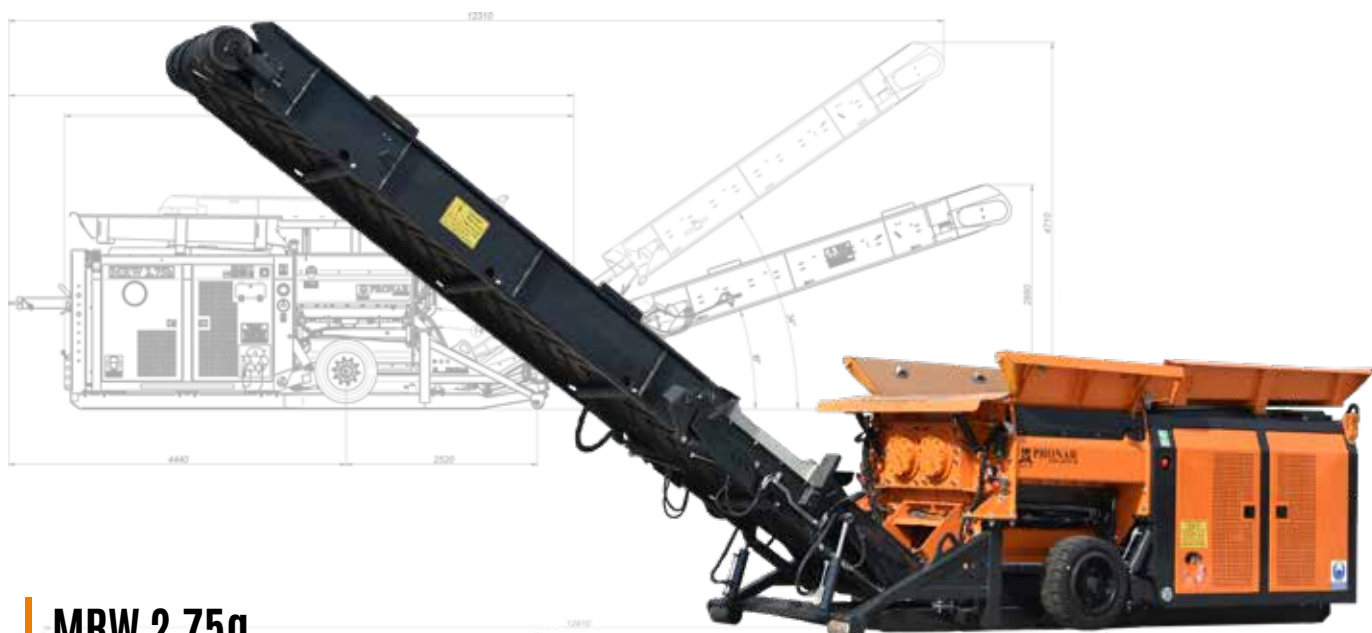

## MRW 2.75g





# mobile slow-speed shredder MRW 2.65

The Pronar MRW 2.65 slow-speed shredder is a machine designed for companies that value the mobility and versatility of the equipment. Various types of easily replaceable shafts are available, allowing the shredder to be adapted to the task at site. Thanks to the hooklift frame (in accordance with the DIN 30722-1 standard) and the tracked chassis, it is possible to easily transport the machine to the workplace, and then move around. Due to its compact size, Pronar MRW 2.65 can work wherever space is limited. This also makes Pronar MRW 2.65 great for rental. The 240 HP Volvo Penta engine installed in the machine allows for smooth operation with various materials. Optimally matched with load sensing hydraulics for the main components of the machine, low fuel consumption is guaranteed.

## KEY FEATURES & BENEFITS

- | easily replaceable shafts in the cassette
- | compact size
- | hook and tracked chassis in one machine
- | low fuel consumption

## APPLICATION

- | wood
- | wood-based materials
- | municipal waste
- | bulky
- | industrial
- | c&d waste
- | asphalt
- | tires
- | thin-walled scrap





## TECHNICAL DATA

## MRW 2.65

Dimensions (length/width/height) [mm]	6967/2276/2639
Weight [kg]	~17000
Number of shafts	2
Shafts length [mm]	1550
Loading height [mm]	~2500
Working chamber dimensions (length/width) [mm]	1620/2340
Hopper capacity [m <sup>3</sup> ]	n/a
Engine	Volvo Penta 5.1l, 175 kW, Stage V/Tier 4 Final

\* Weight depends on the specification of the individual piece and may be higher

## MRW 2.65

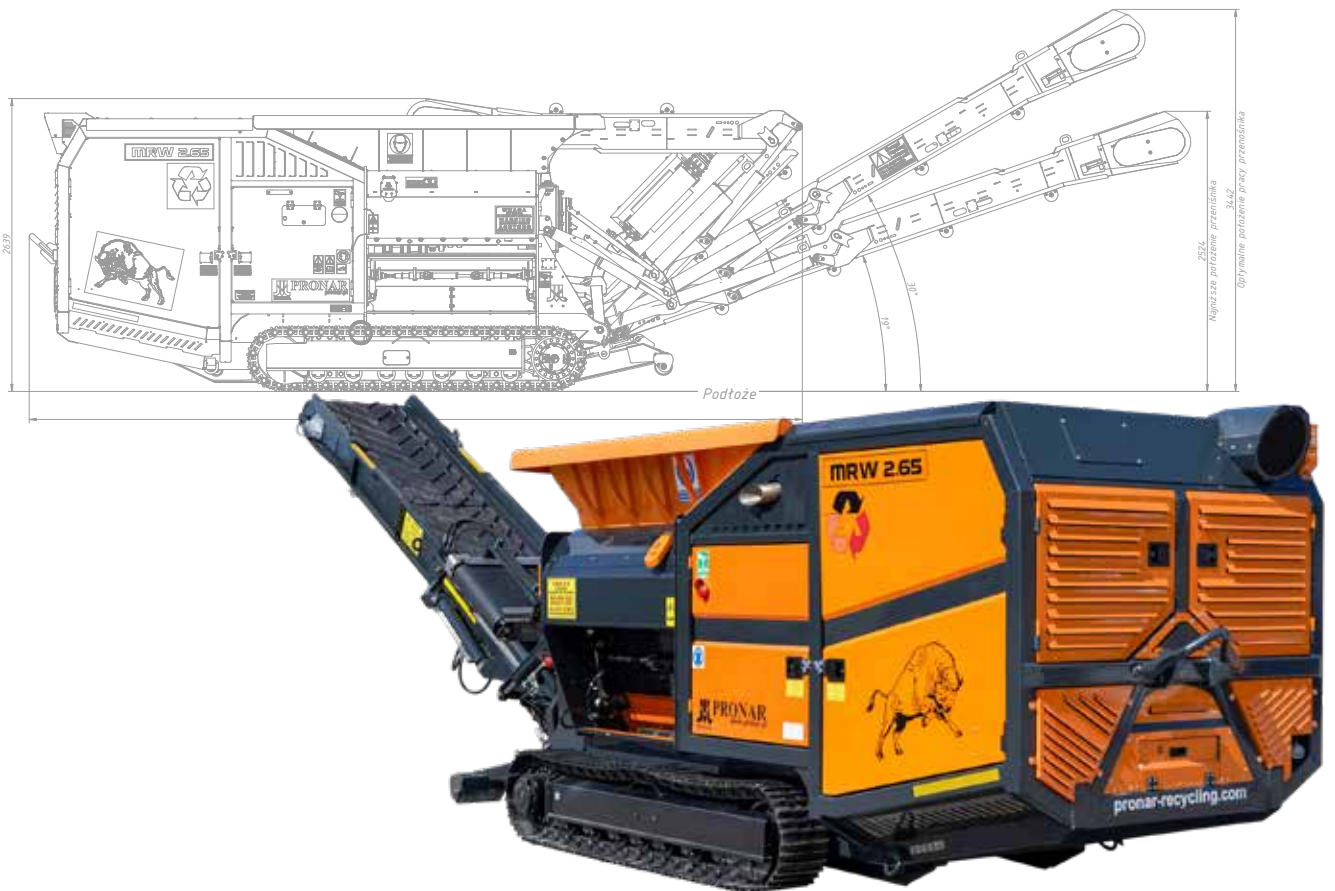



## mobile high-speed shredder MRS 1.53

The Pronar MRS 1.53 mobile high-speed shredder is a machine whose key element is the rotor rotating at a speed of up to 1000 rpm. In the standard version, 36 swinging, easily replaceable hammers adapted to the material being processed are mounted on it. The machine prepared in this way is great for wood-based materials or green waste. In the RDF specification, the standard shaft is replaced with a drum with bolted, fixed knives, making it a mobile mill. In this configuration, the Pronar MRS 1.53 shredder is able to grind the material used later as an alternative fuel. In both versions, screens that determine the final size of the processed material can be installed in front of the shaft. The optional magnetic separator allows the removal of ferromagnetic elements from the final stream that were not separated during the first stage shredding.

### KEY FEATURES & BENEFITS

- | possibility of fraction size adjustment using screens
- | drive anti-overload system
- | easy knife replacement system
- | easy access to the shredding chamber thanks to the low opening feeder
- | possibility of installing a special RDF shaft

### APPLICATION

- | wooden pallets
- | shrubs
- | branches
- | wood-based materials
- | green waste
- | compost





## TECHNICAL DATA

## MRS 1.53

Dimensions (length/width/height) [mm]	11750/2537/3640
Weight [kg]	~27000*
Number of shafts	1
Shafts length [mm]	1750
Loading height [mm]	2400
Working chamber dimensions (length/width) [mm]	3670/2200
Hopper capacity [m <sup>3</sup> ]	n/a
Engine	Volvo Penta 12.8l, 405 kW, Stage V/Tier 4 Final

\* Weight depends on the specification of the individual piece and may be higher

## MRS 1.53





# mobile slow-speed and high-speed shredders SHAFTS FOR A MULTIPLE APPLICATIONS

The shredding shafts used in Pronar MRW and MRS series recycling machines, are solutions tailored to customer's needs. A wide range of shafts to apply them to all the most popular work - shredding municipal waste, construction waste, pallets, light debris, tree stumps, branches, bulky materials or scrap.

The customer can make a choice of either a universal shaft or with knives and hooks designed for a specific type of material. During the production of shafts, the latest technologies are used - including water cutting. This ensures high hardness of the shredding element of the shaft in its entire cross-section. The use of intelligent welding robots allows to achieve perfect weld and high repeatability of movements. Long work without the need of frequent regenerating of the shafts is ensured by the use of high resistance steel.

## Quality checks

Before being put into production, each batch of steel used to make the shafts is tested in the research and development center. Their key parameters are checked, confirming the appropriate steel grade and correct hardness.

## Rings are cut and milled

Each ring is precisely cut on milling machines. In the same time the shaft cores receive their final shape on numerical lathes.

## Knife cutting

Use of water cutting technology allows to maintain physical and chemical properties of the material and for cutting at an angle. As a result, the knives do not have to be additionally hardened. They maintain high hardness all the time.







## Welding

Elements are pre-positioned and spot welded. Later, they are put on the table of the welding robot, which makes the perfect weld while controlling its course. If an error occurs or a deviation is detected, the work is stopped and the previously put weld can be analyzed by the supervising operator.

## Quality check

Each weld on the shafts is checked for proper joint to the metal surface. Only when such control is successful, the shafts are painted.

## Final assembly

The final stage is the assembly of the shafts in the machine. The appropriate design ensures that they do not collide during operation. Together with the working chamber and strong bearings, they create a durable and reliable shredding system.





PRONAR MPB 20.55

PRONAR

MPB 20.55



# MOBILE TROMMEL SCREENS

Mobile trommel screens are machines whose task is to mechanically divide particles based on their size. The input material falling into the rotating drum moves along its perforated surface. Particles smaller than the mesh form the fine fraction, and the larger ones - oversize. As a result, the material is cleaned of various types of dirt. Typical applications for drum screens are compost, wood chips, soil, municipal refuse, coal as well as aggregate.

Pronar MPB drum screens are appreciated by users for their ease of use and servicing, as well as their durability. A wide range of models and numerous options enable a very precise adaptation to the customer's needs.

## KEY FEATURES

- | quick drum change
- | high efficiency due to large screening area
- | smooth change of operating parameters enabling precise setting
- | the possibility of driving on roads without the need for additional permits
- | unmatched mobility in the yard thanks to the tracked chassis





mobile trommel screens

MPB 20.72  | MPB 20.72g

The Pronar MPB 20.72 and MPB 20.72g trommel screens are designed to work in large installations. The 7.2 m long and 2 m diameter drum offers a very large screening area. This guarantees very good results when working with difficult material. The Pronar MPB 20.72 trommel screen in the wheeled version has been designed as a semi-trailer, which makes it easier to transport it with semi-truck. The tracked version, on the other hand, provides comfort in work that requires frequent movement of the machine around the yard.

## KEY FEATURES & BENEFITS

- | designed with large projects in mind
- | large screening area
- | ease of transport
- | good cleaning of even difficult materials
- | ease of servicing
- | short set-up time and the „autostart” function





## TECHNICAL DATA

	MPB 20.72	MPB 20.72g
Trommel dimensions (length/diameter) [mm]	7200/2000	7200/2000
Dimensions (length/width/height) [mm]	12310/2550/3920	12380/2910/3650
Weight [kg]	~25000	~20300
Max trommel rotational speed [rpm]	23 (nie dotyczy wersji z silnikami elektrycznym)	19
Effective sieve surface [m <sup>2</sup> ]	40,6	40,6
Loading height [mm]	2730	2830
In-Feed hopper capacity [m <sup>3</sup> ]	6	6
Engine	CAT 3.6l, 90 kW (122 HP) Stage V/Tier 4 Final; Deutz 3.6l 90 kW (122 HP), Stage V/Tier 4 Final; CAT 3.6l, 90 kW (122 HP), Stage 3A; ABB, 55 kW (75 HP)	CAT 3.6l, 90 kW (122 HP) Stage V/Tier 4 Final; Deutz 3.6l 90 kW (122 HP), Stage V/Tier 4 Final; CAT 3.6l, 90 kW (122 HP), Stage 3A;

## MPB 20.72

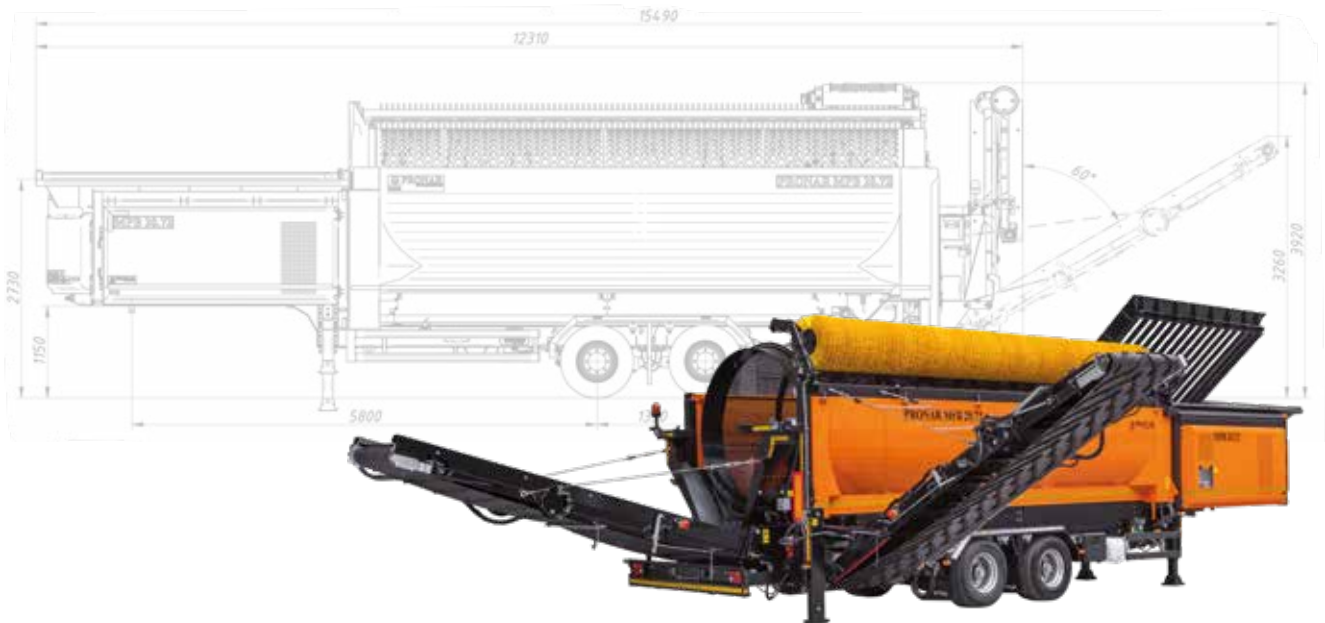

## MPB 20.72g





mobile trommel screens

**MPB 20.55**  | **MPB 20.55g** | **MPB 20.55gh**

The Pronar MPB 20.55, MPB 20.55g and MPB 20.55gh trommel screens are bestsellers addressed to medium and large companies. Regardless of the selected type of chassis, each of these machines allows for optimal screening efficiency and accuracy thanks to a 5.5 m long and 2 m diameter drum. The Pronar MPB 20.55gh machine is additionally equipped with a drum leveling system. Thanks to this, it is possible to screen also on uneven terrain. Changing drum inclination can also help in working with various materials. The list of additional equipment includes a star deck designed for screening wet and sticky material.

## KEY FEATURES & BENEFITS

- | high performance
- | ease of servicing
- | possibility to mount a star deck
- | drum leveling system
- | quick preparation for work and the „autostart” function
- | compatibility with drums of selected manufacturers





TECHNICAL DATA	MPB 20.55	MPB 20.55g	MPB 20.55gh
Trommel dimensions (length/diameter) [mm]	5500/2000	5500/2000	5500/2000
Dimensions (length/width/height) [mm]	120000/2550/3900	10610/2920/3510	10740/3100/3750
Weight [kg]	~16000	~20000	~20840
Max trommel rotational speed [rpm]	30	25	25
Effective sieve surface [m <sup>2</sup> ]	29,8	29,8	29,8
Loading height [mm]	2710	2700	2680
In-Feed hopper capacity [m <sup>3</sup> ]	6	6	6
Engine	CAT 3.6l, 90 kW (122 HP) Stage V/Tier 4 Final; Deutz 3.6l 90 kW (122 HP), Stage V/Tier 4 Final; CAT 3.6l, 90 kW (122 HP), Stage 3A;  ABB, 55 kW (75 HP)	CAT 3.6l, 90 kW (122 HP) Stage V/Tier 4 Final; Deutz 3.6l 90 kW (122 HP), Stage V/Tier 4 Final; CAT 3.6l, 90 kW (122 HP), Stage 3A;	CAT 3.6l, 90 kW (122 HP) Stage V/Tier 4 Final; Deutz 3.6l 90 kW (122 HP), Stage V/Tier 4 Final; CAT 3.6l, 90 kW (122 HP), Stage 3A;

## MPB 20.55

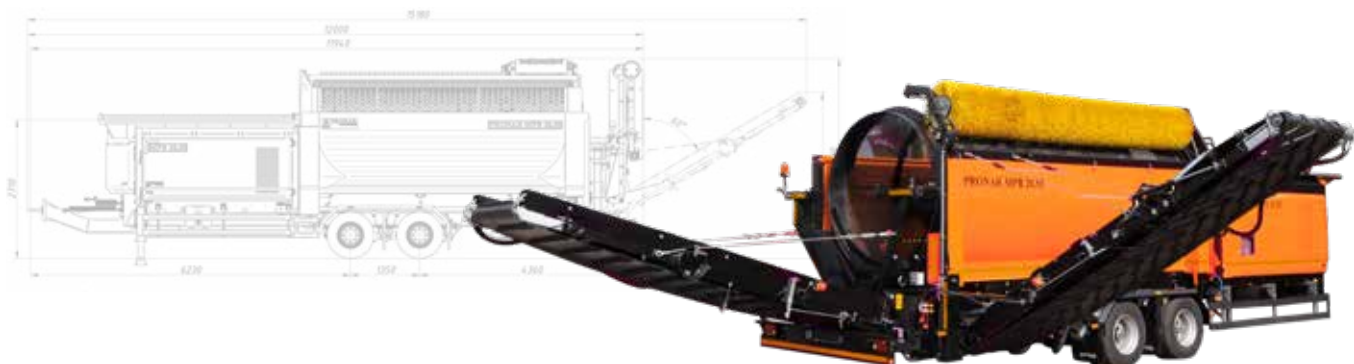

## MPB 20.55g



## MPB 20.55gh

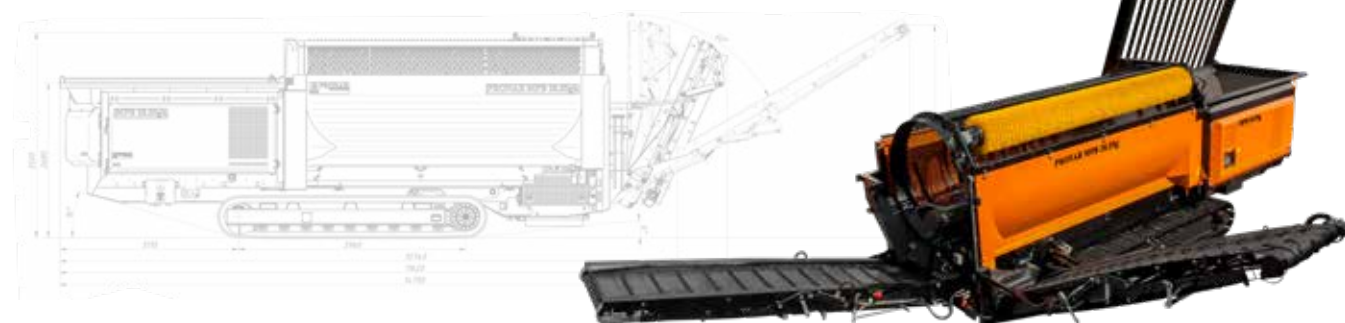



mobile trommel screens

MPB 18.47  | MPB 18.47g

The Pronar MPB 18.47 and MPB 18.47g trommel screens are addressed to small and medium-sized companies dealing with widely understood recycling. The 4.7 m long and 1.8 m diameter screening drum enables efficient and accurate screening. The CAT 2.8 engine allows for smooth operation without the need for frequent refueling. The list of additional equipment also includes an electric motor. Thanks to it, the costs of current operation and periodic inspections can be significantly reduced. The version with a tracked chassis provides unparalleled convenience in moving the machine during operation.

## KEY FEATURES & BENEFITS

- | the possibility of hauling the machine on the road without additional permits
- | tracked version available
- | easy service access
- | performance tailored to the needs of small and medium-sized companies
- | short set-up time and the „Autostart” function
- | compatibility with drums of selected manufacturers





## TECHNICAL DATA

	<b>MPB 18.47</b>	<b>MPB 18.47g</b>
Trommel dimensions (length/diameter) [mm]	4700/1800	4700/1800
Dimensions (length/width/height) [mm]	10990/2550/3850	9530/2920/3450
Weight [kg]	~12800	~14000
Max trommel rotational speed [rpm]	23	23
Effective sieve surface [m <sup>2</sup> ]	22,1	22,1
Loading height [mm]	2700	2660
In-Feed hopper capacity [m <sup>3</sup> ]	5	5
Engine	CAT 2.8i, 55 kW (75 HP), Stage V/Tier 4 Final; Deutz 2.9i, 55,4 kW (75 HP), Stage V/Tier 4 Final; ABB, 30 kW (41 HP); ABB, 45 kW (61 HP)	CAT 2.8i, 55 kW (75 HP), Stage V/Tier 4 Final; Deutz 2.9i, 55,4 kW (75 HP), Stage V/Tier 4 Final; ABB, 30 kW (41 HP);

## MPB 18.47



## MPB 18.47g





# mobile trommel screen MPB 18.47/1

The PRONAR MPB 18.47/1 mobile trommel screen is a machine designed for users looking for a product with very good parameters, attractive price and simple build. The simplicity of its design, versatility, and affordable price make it a great choice for small companies that direct their steps towards recycling jobs. Additionally, a full warranty is a valid argument in favor of choosing the Pronar MPB 18.47/1 over the worn-out aftermarket machine. This simple screen is also an interesting proposition for already developed companies that are looking for a machine for occasional screening or support for their fleet during an intense season.

## KEY FEATURES & BENEFITS

- | a favorable price calculated
- | low running costs
- | compatible with selected manufacturers' drums
- | the low loading height makes it easier to work with small loaders





TECHNICAL DATA	MPB 18.47/1
Trommel dimensions (length/diameter) [mm]	4700/1800
Dimensions (length/width/height) [mm]	13860/2340/2630
Weight [kg]	~12800
Max trommel rotational speed [rpm]	23
Effective sieve surface [m <sup>2</sup> ]	22,1
Loading height [mm]	2100/3000
In-Feed hopper capacity [m <sup>3</sup> ]	5
Engine	Deutz 2.9l, 55,4 kW (75 HP), Stage V/Tier 4 Final; CAT 2.8l, 55 kW (75 HP), Stage V/Tier 4 Final

## MPB 18.47/1

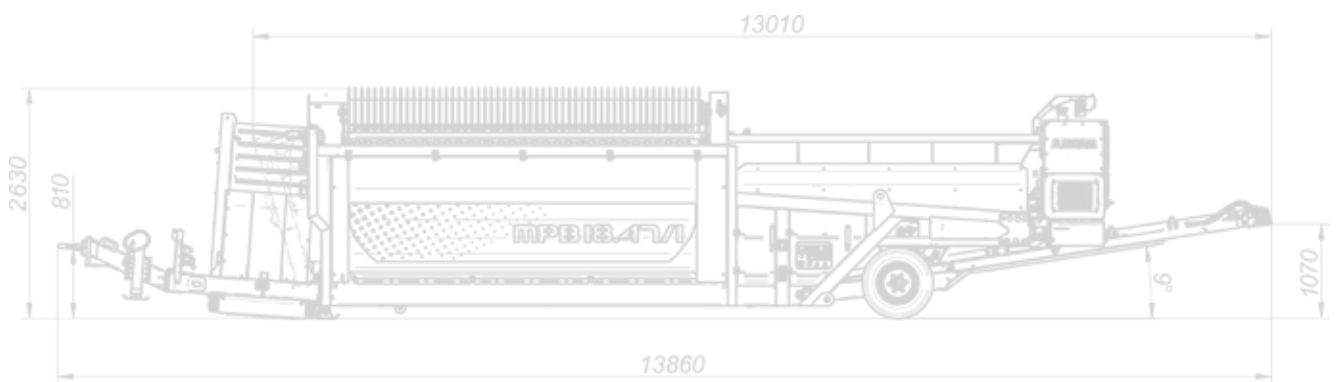



mobile trommel screen

**MPB 14.44** 

The Pronar MPB 14.44 mobile trommel screen is machine for customers looking for a small and very compact equipment. The drum with a length of 4.4 m and a diameter of 1.4 m in combination with a hopper with a capacity of 3.3 m<sup>3</sup> guarantees effective work wherever large machines do not have room. The CAT 1.7 engine efficiently drives all systems without consuming much fuel. The possibility of ordering the Pronar MPB 14.44 trommel screen with an electric motor additionally reduces the operation costs. It also require less complex periodic inspections.

## KEY FEATURES & BENEFITS

- | low fuel consumption
- | easy service access
- | the possibility of hauling the machine on the road without additional permits
- | quick preparation for work and the „autostart” function
- | can be ordered with an electric motor
- | compact size





## TECHNICAL DATA

## MPB 14.44

Trommel dimensions (length/diameter) [mm]	4400/1400
Dimensions (length/width/height) [mm]	10690/2250/3860
Weight [kg]	~11000
Max trommel rotational speed [rpm]	23
Effective sieve surface [m <sup>2</sup> ]	16
Loading height [mm]	2580
In-Feed hopper capacity [m <sup>3</sup> ]	3,3
Engine	CAT 1.7l, 35 kW (47 HP), Stage V/Tier 4 Final; ABB, 30 kW (41 HP)

## MPB 14.44

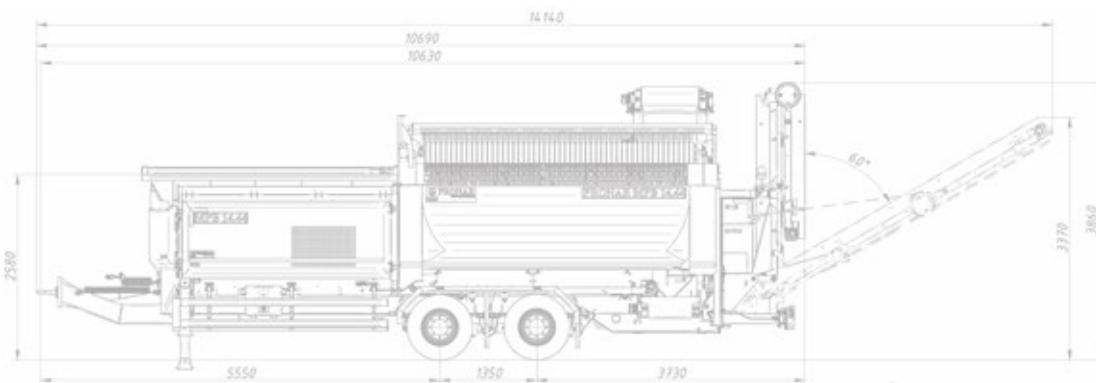

RECYCLING EQUIPMENT RANGE



MOBILE TROMMEL SCREENS



# mobile trommel screens DRUMS

Pronar MPB Trommel drums may be easily changed to suit material screening requirements. Pronar also produces screen drums compatible with other manufacturers' machines.

Depending on the screened material: soil, compost, municipal waste, aggregate, biomass; different types of perforation are available, shapes include round or square, any size hole available.

## Sheet of metal arrives

The screen starts its life as a flat sheet. We use 6 to 10 mm thick sheet of metal for production. Depending on the density of the perforation and its size, we recommend different thicknesses.

## Laser cutting

The sheet of metal goes to the laser cutter. There, the entire perforation is cut out. Due to the technology used, any shape and size can be made.

## Rolling

The perforated sheet goes to the rolling mill, which gives it a round shape. Strong rollers can bend even a thick sheet.





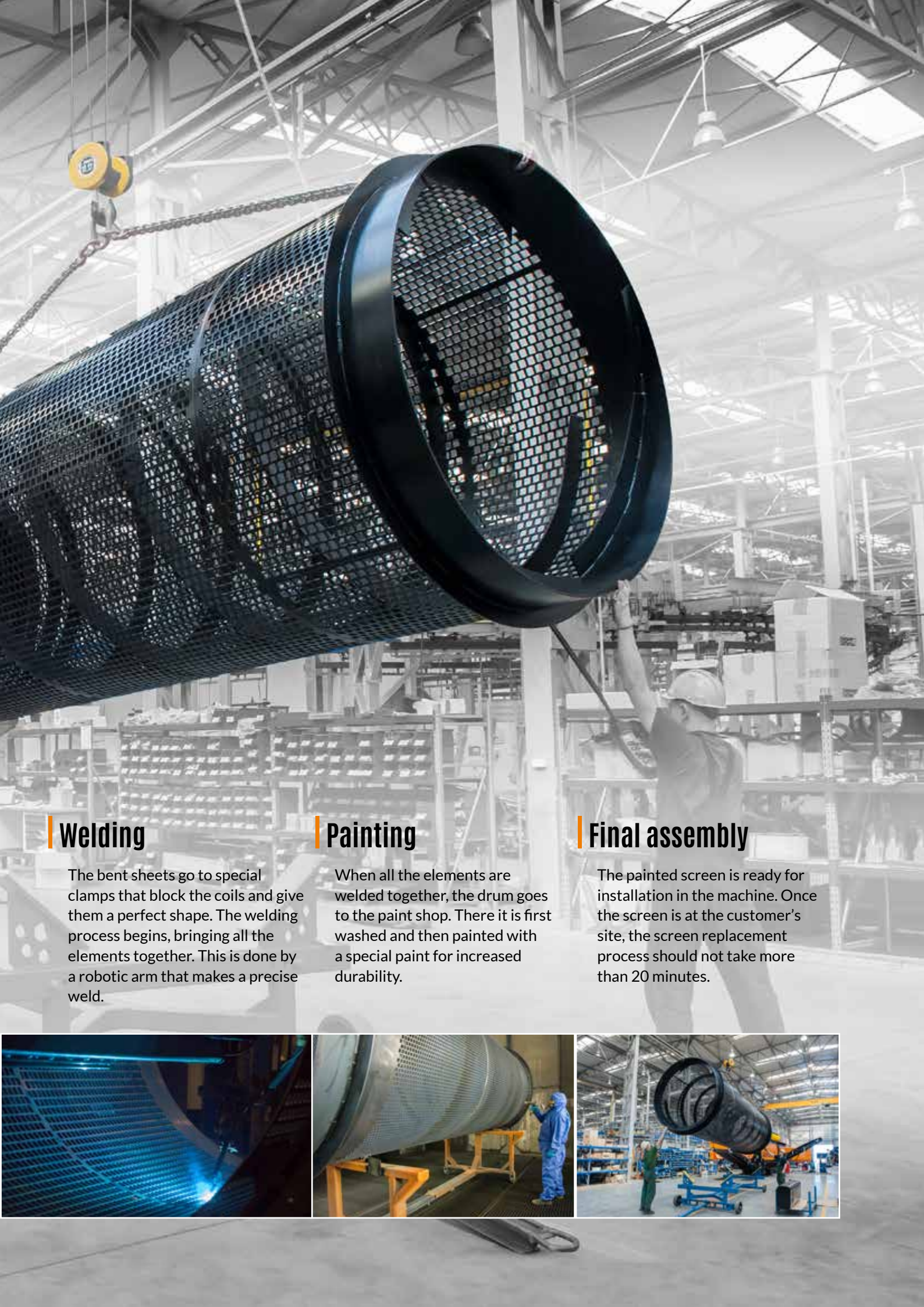

## | Welding

The bent sheets go to special clamps that block the coils and give them a perfect shape. The welding process begins, bringing all the elements together. This is done by a robotic arm that makes a precise weld.

## | Painting

When all the elements are welded together, the drum goes to the paint shop. There it is first washed and then painted with a special paint for increased durability.

## | Final assembly

The painted screen is ready for installation in the machine. Once the screen is at the customer's site, the screen replacement process should not take more than 20 minutes.







## mobile trommel screens **STAR SCREEN**

The star deck can be used interchangeably with the drum screen. It is especially suitable for screening wet material, but it is also able to replace the drum when working with loose material. The speed of the stars transporting the material is infinitely adjustable, which allows to precisely determine the size of the separated fraction.

### **APPLICATION**

- | municipal and industrial waste, compost,
- | shredded roots, wood, bark,
- | contaminated aggregates: sand, gravel, clay, stones, soil, peat, coal,
- | raw materials for substrates for road or gardening works







## windrow turner **MBA 4512g**

The PRONAR MBA 4512g mobile compost turner is used to optimize the parameters of biological compost decomposition on piles. It accelerates this process by releasing excess heat, allowing water to evaporate or additional wetting of the material, aerating and loosening the turned waste.

The shaft with a diameter of 1.2 m allows you to achieve a capacity of about 3000 m<sup>3</sup>/h of compost on heaps up to 4.5 m wide and up to 2.2 m high. The shaft can rotate at speeds up to 200 rpm. The direction of the shaft spinning can be changed at any time by the user, also during material turning. Every element susceptible to premature wear is made out of wear-resistant steel to increase their lifetime.

### **KEY FEATURES & BENEFITS**

- | comfortable operator's cabin
- | easy operation with joysticks and touch screen
- | air conditioning as standard
- | convenient and safe service platforms
- | the air cleaning system in the cabin meets the EN-15695 cat.4 standards





## TECHNICAL DATA

## MBA 4512g

Weight [kg]	~14500
Dimensions (length/width/height) [mm]	4000/5000/4600
Shaft diameter [mm]	1200
Max. width of prism [mm]	4500
Max. height of prism [mm]	2200
Speed of the shaft [rpm]	0-220
Efficiency [m <sup>3</sup> /h]	3200
Engine	Volvo Penta 7.7l, 160 kW, Stage V/Tier 4 Final

## MBA 4512g

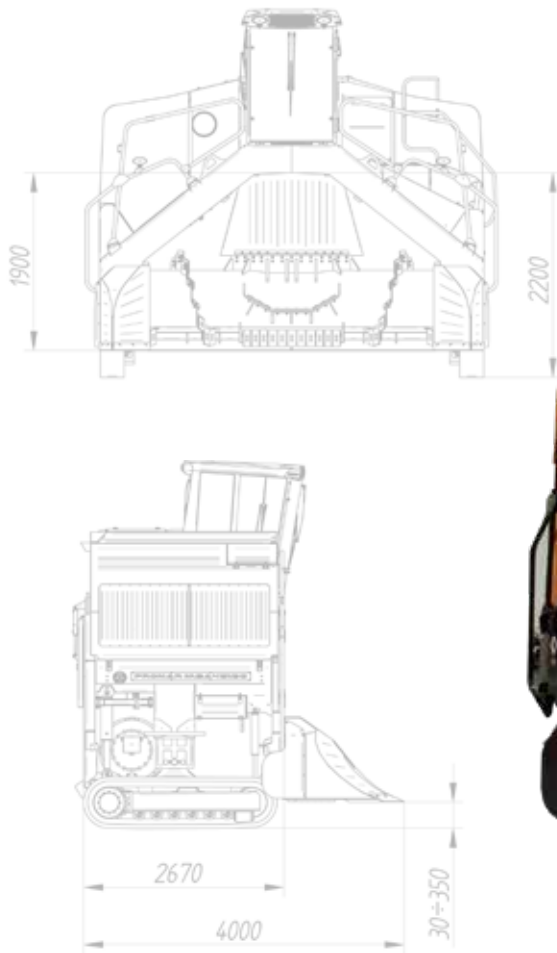



**PRONAR**  
SPECIALIZED TRACKED CONVEYORS



# VIBRATING SCREENS AND CRUSHERS

Mobile scalpers and final screens, as well as jaw and impact crushers are mandatory machines in companies that do quarrying or recycle aggregate. The equipment that is able to move independently increases the usability of the installation by allowing it to work in different parts of it. What is more the possibility of easy transport gives the opportunity of hassle-free rental or work on projects in remote locations.

Vibrating screens and crushers by Pronar are equipment developed by engineers with many years of experience in designing big and heavy recycling machines. The enormous possibilities of the factory producing them and modern production technologies allow us to provide customers with a well-thought-out product designed for many years of operation, even in very difficult conditions.

## KEY FEATURES & BENEFITS

- | using modern technologies for production
- | basing the structure on proven and well-tested solutions
- | designed with ease and safety of operation in mind
- | short set-up time





## vibrating screen MPP 1238s

Pronar MPP 1238s scalping screen is a machine designed for first-stage screening. Two long decks enable precise separation of the material into three fractions. The speeds of each hydraulically driven element, adjustable via a touchscreen, and easy to change inclination of the screenbox allow for smooth and precise adjustment of operating parameters to a given type of material. The 3.6-liter engine with 136 HP is able to cope with even a heavy load without the need to use high revs. The vibrating box lifting system and the side tensioning of both the upper and lower deck ensure easy access and a short set-up time. Once at its destination, the operator needs no more than 10 minutes for the screen to start working.

### KEY FEATURES & BENEFITS

- | throughput up to 350 t/h
- | maximum feed size up to 500 mm
- | easy assembly disassembly and screen tensioning system
- | intuitive touch screen operation
- | full control over all machine parameters
- | remote control as standard
- | hydraulic drive using a load sensing pump for lower fuel consumption
- | set up time in under 10 minutes
- | possibility to work in front of the crusher thanks to folding rear hopper wall
- | lift-up screenbox for easier set-up and service
- | possibility to work in a 3- or 2-way split

### OPTIONS

- | apron feeder in the charging hopper
- | central lubrication
- | screen media depending on the customer's needs





## TECHNICAL DATA

## MPP 1238s

Dimensions (length/width/height) [mm]	12920/13640/12920
Transport dimensions (length/width/height) [mm]	12980/2550/3390
Weight [kg]*	~21000
Deck dimensions (length/width) [mm]	3800/1250
Performance up to (t/h)**	350
Oversize conveyor [mm]	1000
Mid-size conveyor [mm]	800
Fines conveyor [mm]	800
Engine	CAT 3.6, 100 kW, Stage V/Tier 4 Final

\* Weight depends on the specification of the individual piece and may be higher

\*\* Throughput performance depends on screened material

## MPP 1238s

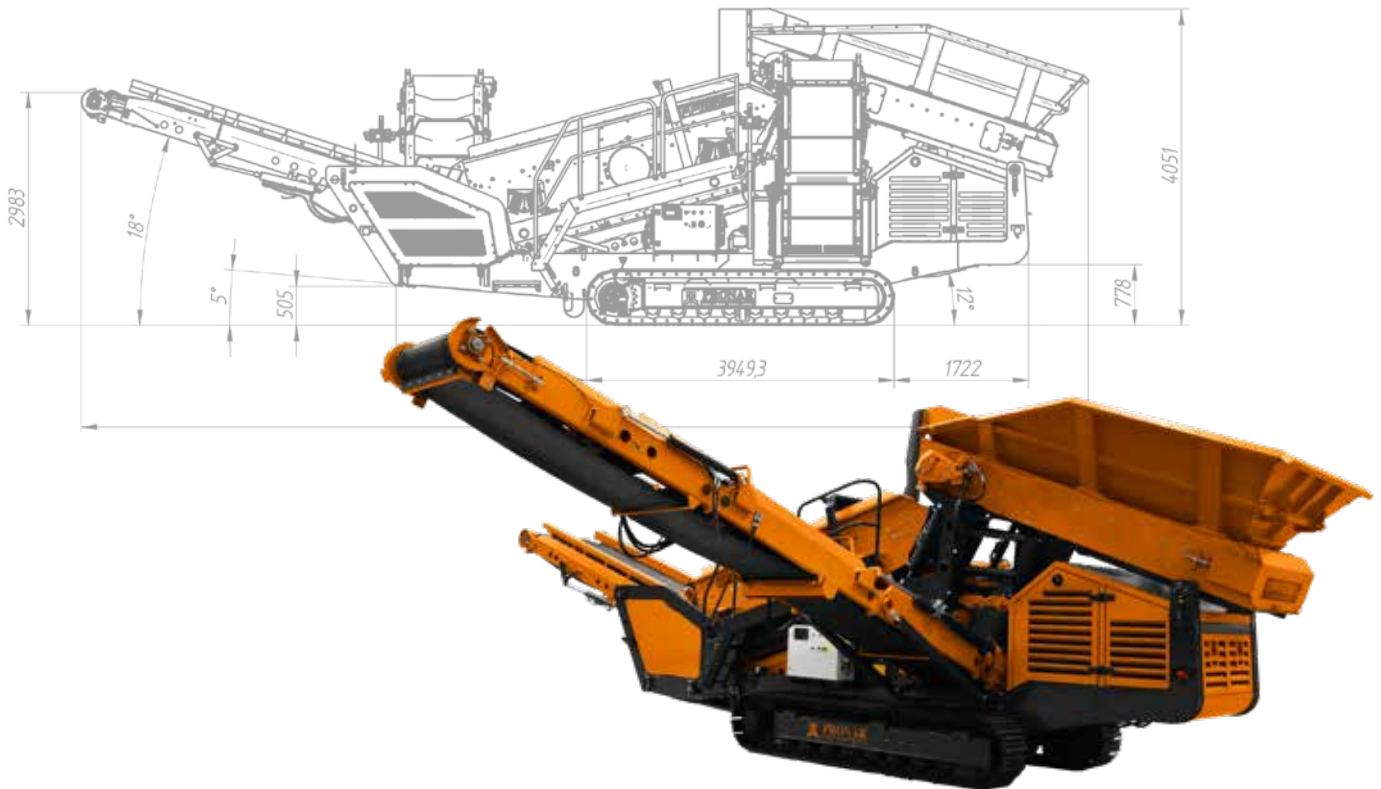



# jaw crusher MJC 6510

The Pronar MJC 6510 jaw crusher is a machine designed for first stage crushing. The dimensions of the inlet to the crushing chamber are 1015x650. This allows to work with input material sizes of 500-600 mm without the risk of clogging and unnecessary downtime. Hydraulic adjustment of the gap between 30 and 120 mm allows for easy and quick adjustment of the machine to work with various materials. Big space between the chamber and the main feeder ensures a smooth flow of material without the risk of clogging. The fine fraction pre-screening system improves the crushing quality and extends the life of the linings. The possibility of setting many operating parameters using a wireless remote control increases not only the comfort of work, but also the operator's safety.

## KEY FEATURES & BENEFITS

- | hydraulic gap adjustment
- | reversing system
- | extensive remote control
- | key components driven by load sensing pumps
- | pre-screening system
- | short set-up time

## OPTIONS

- | magnetic separator
- | recycling plate
- | central lubrication
- | sprinkler system
- | main and side conveyor with increased discharge height (by +0.6 m and +0.8 m respectively)
- | hydraulic oil heater





## TECHNICAL DATA

## MJC 6510

Crusher type	jaw crusher
Dimensions (length/width/height) [mm]	12900x2550x3230
Weight [kg]	~33000
CRUSHING	
Inlet (width/length) [mm]	1015x650
Gap adjustment	hydraulic
CSS (min-max) [mm]	30-120
Feed size (up to) [mm]	600
CONVEYORS	
Main conveyor width [mm]	1000
Main conveyor discharge height [mm]	3200
Side conveyor width [mm]	650
Side conveyor discharge height [mm]	2100
DRIVE	
Engine	CAT
Displacement	7.1
Power	186 kW (256 HP)

## MJC 6510





pronar-recycling.com

**PRONAR**  
PRONAR.pl

**MPT18g**

**PRONAR**  
PRONAR.pl

0



# MOBILE STOCKPILERS

Belt conveyors are machines that allow you to make a high pile of material quickly or help transport the material between two places. Their use in the yard means savings in operational costs and increases the level of safety. Compared to a loader used to form piles, they burn less fuel, require no operator for continuous operation, and inspections are much simpler and cheaper.

Mobile stockpilers from the Pronar MPT series give the customer wide choice when it comes to size and guarantee of solid construction. Depending on the model, the maximum capacity is up to 600 t/h. This allows to work with highly efficient screens or crushers, as well as even direct loading.

## KEY FEATURES

- | reducing the cost of making piles
- | increasing the level of safety in the yard
- | low fuel consumption
- | low operating costs
- | possibility to build larger piles faster than with a loader





## mobile stockpilers MPT 18g | MPT 24g



Belt conveyors MPT 18g and MPT 24g from the Heavy Duty series are machines for customers looking for solutions with above-average durability and high efficiency. Thanks to the well-thought-out design and the use of a 2.8 CAT engine (55 kW at 2500 rpm), it is possible to move up to 600 tons of material per hour. The radio control of the machine is already available as standard, and it can be optionally equipped with direct hopper that allows to work with the front loader. The undoubted advantage of Pronar conveyors is their easy transport. The possibility of transporting it in a 40 'HQ sea container significantly improves the machine reaching the other end of the world.

### KEY FEATURES & BENEFITS

- | durable construction
- | possibility of loading with a front loader
- | a direct feeding hopper with a volume of up to 12 m<sup>3</sup>
- | efficient drive
- | easy transport
- | wireless remote control as standard





TECHNICAL DATA	MPT 18g	MPT 24g
Conveyor length (total construction length) [m]	19,3	23,4
Throughput max [t/h]	500	600
Discharge height [m]	8,7	11,3
Tilt angle max	25,2	27,2
Belt width [mm]	1000	1000
Weight [kg]	13800	15600
Dimensions (length/width/height) [mm]	11860/2250/2557	11910/2250/2550
Engine	CAT 2.8l, 55,4 kW (75 HP), Stage V/Tier 4 Final	CAT 2.8l, 55,4 kW (75 HP), Stage V/Tier 4 Final

## MPT 18g



## MPT 24g





## mobile stockpiler MPT 30/1g

The Pronar MPT 30/1g mobile belt conveyor is the largest conveyor model in the offer. It allows you to build a 13 m high pile. 30 meters of belt length and a capacity of up to 500 t/h make the machine perfect for even large installations where the mobility of the equipment is important. The undoubted advantage of Pronar MPT 30/1g is the possibility of folding it to dimensions that allow sea transport in a 40'HQ container.

### KEY FEATURES & BENEFITS

- | piling 13 m high prisms
- | performance level matched to the most common sizes of screens and crushers
- | efficient engine
- | possibility of transport in a 40 ,HQ sea container
- | possibility to install extensions on the charging hopper





**TECHNICAL DATA****MPT 30/1g**

Conveyor length (total construction length) [m]	30,6
Throughput max [t/h]	500
Discharge height [m]	13
Tilt angle max	25
Belt width [mm]	1000 (1050)
Weight [kg]	15750
Dimensions (length/width/height) [mm]	12629/2950/3261
Engine	CAT 2.8l, 55,4 kW (75 HP), Stage V/Tier 4 Final, Dual power

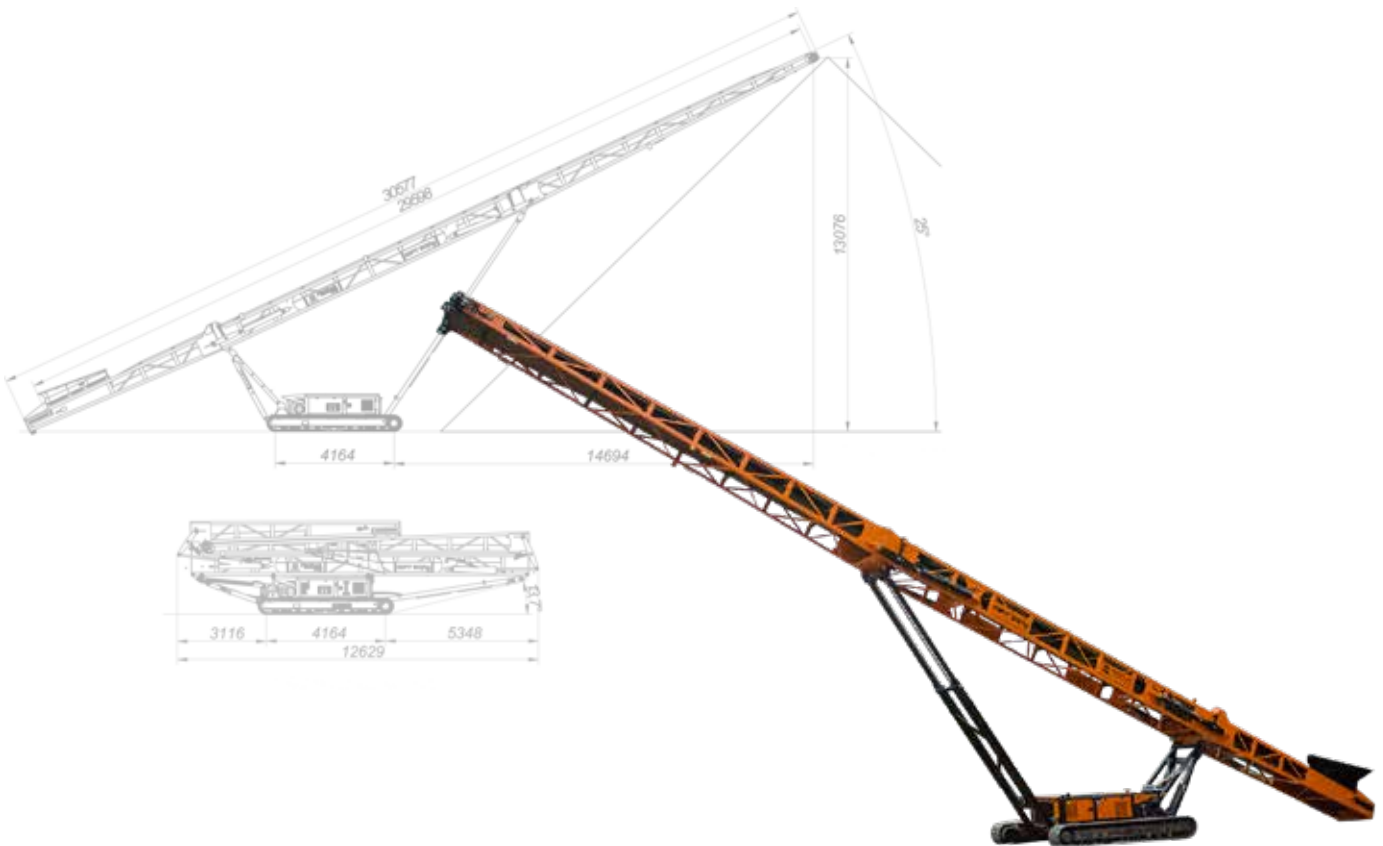
**MPT 30/1g**



mobile stockpilers

**MPT 24/1g | MPT 18/1g | MPT 15g**

Belt conveyors MPT 15g, MPT 18/1g, MPT 24/1g are machines designed with low operating costs, lower weight and compact dimensions in mind. The capacity of 400 t/h allows you to transport quickly the material over long distances and to pile a pile with a maximum height of 7.4 m, 8.7 m, 10.6 m, respectively. The use of a 1.7 l and 36 kW CAT engine guarantees low fuel consumption and easy access service all around the world. All MPTs in this series are equipped with a Stage V compliant drive and fit in a 40' HQ sea container without disassembly.

## KEY FEATURES & BENEFITS

- | Making piles over 10 m high
- | Designed to work in line with crusher or a screener
- | Engine with low fuel consumption
- | Possibility of transport in a 40' HQ sea container
- | Possibility to install extensions on the charging hopper





TECHNICAL DATA	MPT 15g	MPT 18/1g	MPT 24/1g
Conveyor length (total construction length) [m]	16,3	19	23,5
Throughput max [t/h]	400	400	400
Discharge height [m]	7,4	8,7	10,6
Tilt angle max	27	27	26,5
Belt width [mm]	900	900	900
Weight [kg]	9100	9720	11700
Dimensions (length/width/height) [mm]	11857/2259/2411	11857/2249/2441	11885/2249/3162
Engine	CAT 1.7i, 36 kW (47 HP), Stage V/Tier 4 Final	CAT 1.7i, 36 kW (47 HP), Stage V/Tier 4 Final	CAT 1.7i, 36 kW (47 HP), Stage V/Tier 4 Final

## MPT 15g

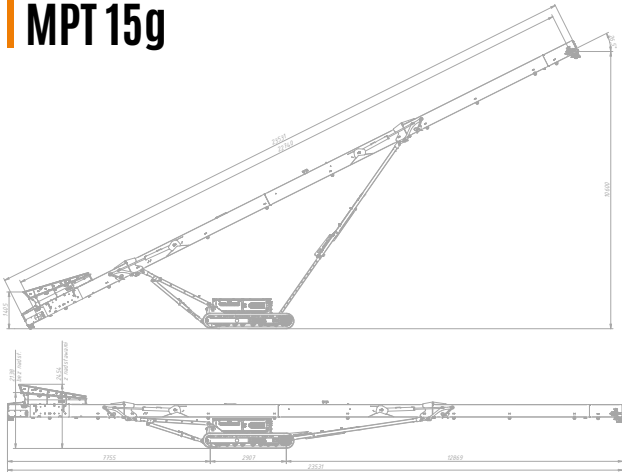

## MPT 18/1g

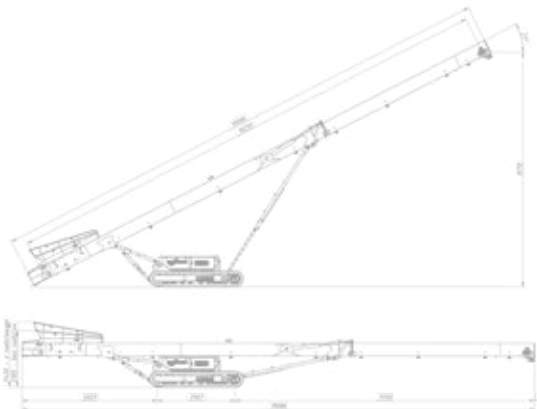

## MPT 24/1g

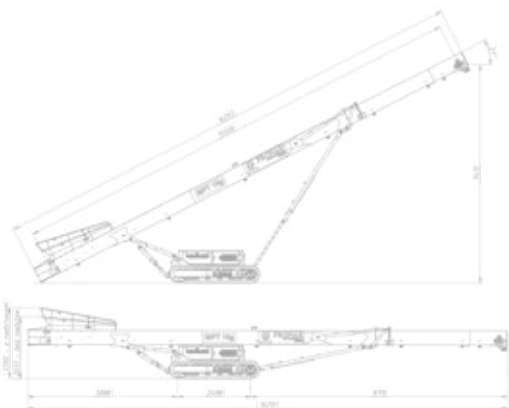



## stationary slow-speed shredder RW 2.85s

Stationary slow-speed shredder Pronar RW 2.85s is designed for shredding various types of materials. Working as a permanent element of the sorting line, the Pronar RW 2.85s shredder acts mainly as a bag opener and reduces the volume of waste before its further sorting and processing. As standard, it is equipped with stable bases on which it is mounted to the ground. The main source of drive is an electric motor. Pronar RW 2.85s has a hydraulically lifted hopper controlled by a remote control. Grinding is performed by means of synchronously working shafts selected depending on the processed material. Steel working elements are made of high-strength, wear-resistant materials, which ensures long and trouble-free operation of the machine.

### KEY FEATURES & BENEFITS



- | can be installed in an existing installation
- | zero emission
- | multi-tasking: the ability to work as a shredder and bag opener
- | high-strength and wear-resistant materials
- | high performance





## TECHNICAL DATA

## RW 2.85s

Dimensions (length/width/height) [mm]	5783/3640/2611
Weight [kg]	~16000*
Number of shafts	2
Shafts length [mm]	1700
Loading height [mm]	2480
Working chamber dimensions (length/width) [mm]	1720/2340
Hopper capacity [m <sup>3</sup> ]	~3
Engine	 ABB, 250 kW + 22 kW  ABB 160 kW + 22 kW

## RW 2.85s

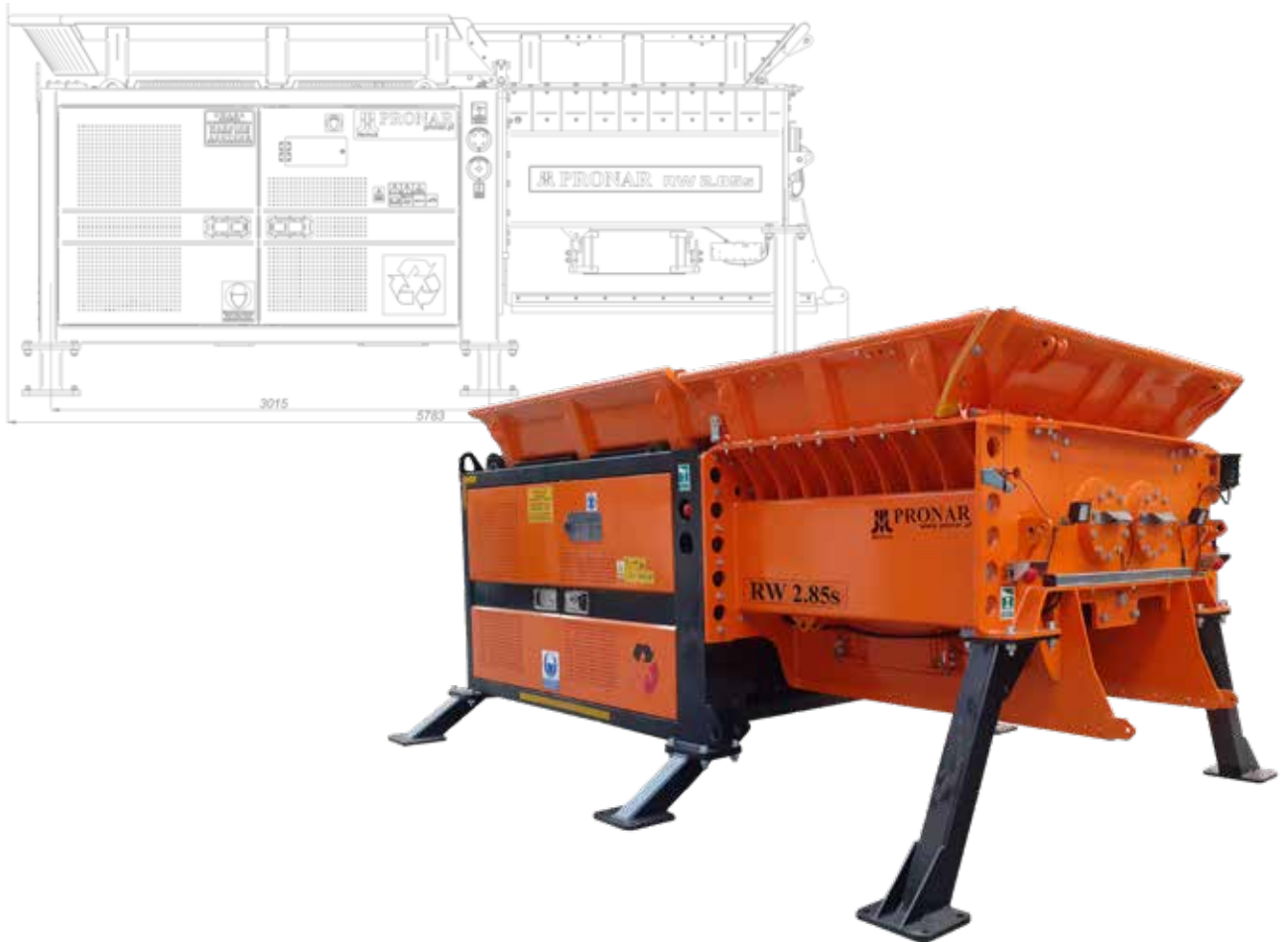



## hydraulic channel baling press HPBK-67HA

The main principle of operation of a hydraulic baling press is based on a cylinder that moves in the channel. Its movement is forced by a hydraulic cylinder with high crushing force. The press cylinder compresses the material in the chamber, then is retracted and the cycle is repeated when the chamber is refilled. After obtaining the appropriate - pre-programmed - bale length, the machine starts the automatic four-fold binding system. A bale with a width of 1,100 mm, a height of 750 mm and a length of 600 to 1,200 mm is pushed out of the chamber by another forming bale.

The Pronar HPBK-67HA press is not only modern, but also safe to use. The machine is practically maintenance-free (except for the need to refill the wire). Compacting is done automatically. The door to the crushing chamber is closed and secured with a special lock. The Pronar HPBK-67HA baler is also convenient to use. Its operating parameters are set using a 10.4" touch. The technology used here allows you to use it without removing protective gloves.

### KEY FEATURES & BENEFITS

- | high crushing force
- | up to 90% material volume reduction
- | automated binding process
- | convenient touch screen showing all key parameters
- | optional loading feeder





## TECHNICAL DATA

## HPBK-67HA

Maximum crushing force [kN]	635
Binding	fourfold, horizontal, automatic
Weight of the bale (depends on the material) [kg]	550
Engine power [kW]	37
Volume reduction (depends on the material) [%]	90
Bale size (H/W/L) [mm]	750/1100/600-1200
Dimensions(length/width/height) [mm]	8640/4070/3870
Loading hole dimensions (W/L) [mm]	1050/1530
Length of pressing channel [mm]	2670

## HPBK-67HA





**WE  
MAKE  
RECYCLING  
EASY.**

**PRONAR Sp. z o.o.**

 **ul. Mickiewicza 101A | 17-210 Narew | Poland**

 **+48 85 682 71 00**

**PRONAR-  
RECYCLING  
.COM**

We constantly improve our machines. That is why we reserve the right to make changes to this publication without prior notice. All performance figures and technical data in this brochure are for illustration purposes only and may not be subject to any claims. This publication is not a binding offer.